



# Republic Vacuum Pump

## VRT-3140

**R E P U B L I C**  
Vacuum Pumps®

Republic offers the VRT-3140 dry running rotary vane vacuum pump with integral suction air filter. Sound cover reduces noise level, enhances cooling and protects operator from touching hot surfaces. Flexible connections possible, low pulsation, easy to operate, maintain and install.



### Advantages

- ▲ Absolutely oil free
- ▲ Free moving vanes
- ▲ Lower Initial Cost
- ▲ Higher Vacuum Capabilities

### Product Options

- ▲ Air filter (recommended)
- ▲ Vacuum regulating valve
- ▲ Non-return valve

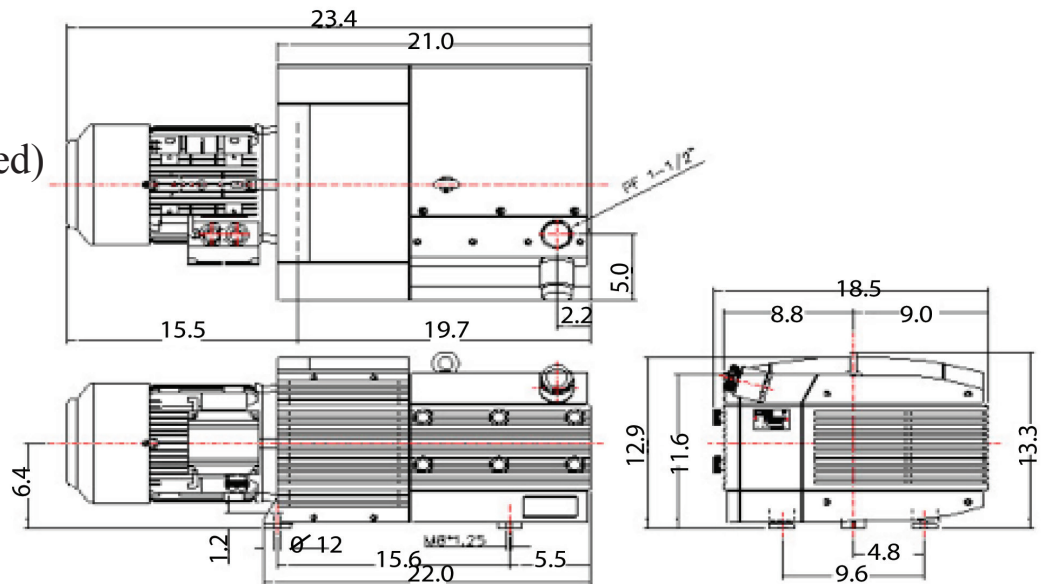

Model	Capacity Max cfm		Ultimate Vacuum Max. (in Hg)		Motor Output Full Load (HP)		Voltage 3Phase (V)		Noise Level (dB)		Weight (lb)
	50 Hz	60 Hz	50 Hz	60 Hz	50 Hz	60 Hz	50 Hz	60 Hz	50 Hz	60 Hz	
VRT-3140	75.3	89.8	22.0	22.0	5.0	7.5	220/380	230/460	76	79	249



# Republic Pressure Pump VRT-3140

REPUBLIC  
Vacuum Pumps®

## VRT-3140 Vacuum Curves

— 60 Hz  
- - 50 Hz

