



# REPUBLIC

Vacuum Pumps®

# Republic Vacuum Pump RX 202

Republic offers the RX 202 oil lubricated rotary vane vacuum pump. Single stage, air-cooled, and direct-driven, the design is one of the most reliable and simplest pumps available.

## Advantages

- ▲ Continuous Duty
- ▲ Simple Maintenance
- ▲ Higher Vacuum Capabilities
- ▲ Easy to Install
- ▲ Quiet Operation



## Product Options

- ▲ Air Filter (recommended)
- ▲ Vacuum Regulating Valve
- ▲ Exhaust Silencer
- ▲ Vacuum Gauge

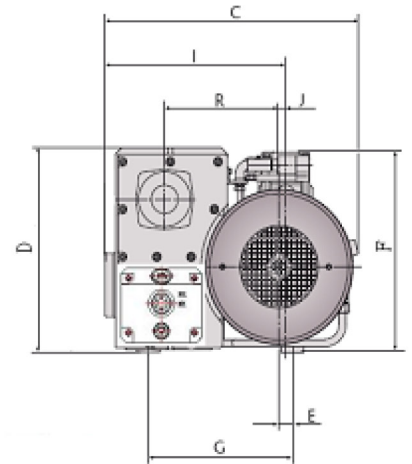
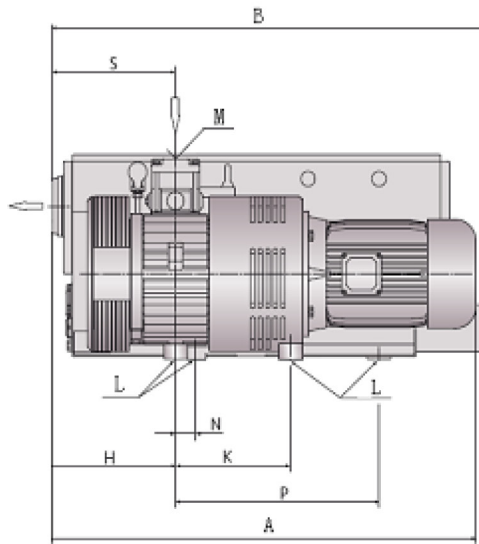

A	B	C	D	E	F	G	H	I	J	K	L	M	N	P
32.87	33.66	19.49	17.12	0.98	16.73	12.20	8.86	13.58	0.59	9.45	4*M10	2	1.38	16.53

Model	Capacity Max cfm		Ultimate Vacuum Max. (in Hg)		Motor Output Full Load (HP)		Voltage 3Phase (V)		Noise Level (dB)		Weight (lb)
	50 Hz	60 Hz	50 Hz	60 Hz	50 Hz	60 Hz	50 Hz	60 Hz	50 Hz	60 Hz	
RX-202	118.0	141.0	29.92	29.92	5.35	7.5	220-380	230-460	73.0	73.0	435



# Republic Vacuum Pump RX 202

REPUBLIC  
Vacuum Pumps®

## RX 202 Vacuum Curves

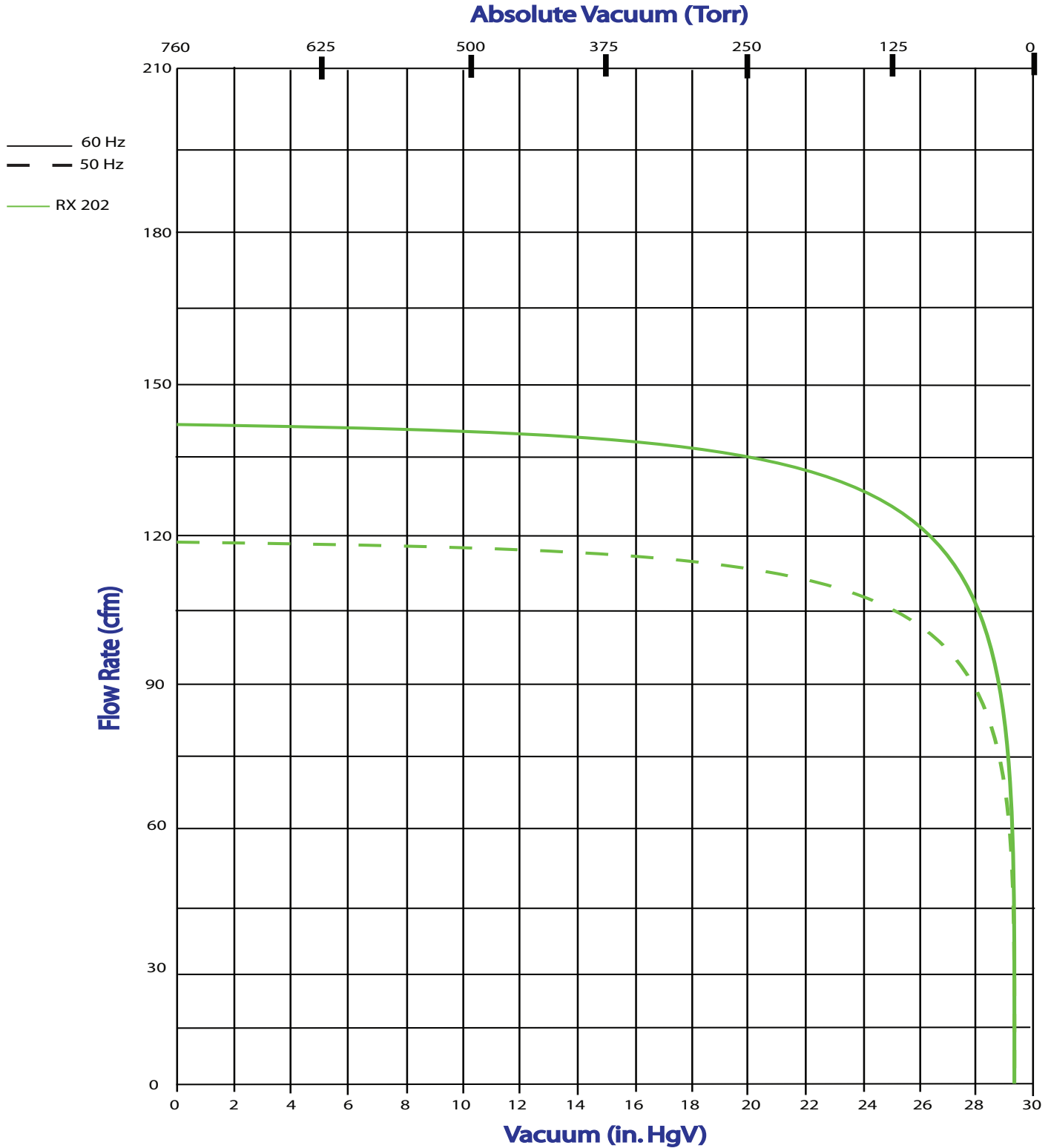

5131 Cash Road ▲ Dallas, TX 75247 ▲ P 214.631.8070 ▲ F 214.631.3673 ▲ 800.847.0380

[www.republicsales.com](http://www.republicsales.com)

©Republic Vacuum Pumps®  
Created 04.2013