



REPUBLIC

Vacuum Pumps®

Republic Vacuum Pump RX 160

Republic offers the RX 160 oil lubricated rotary vane vacuum pump. Single stage, air-cooled, and direct-driven, the design is one of the most reliable and simplest pumps available.

Advantages

- ▲ Continuous Duty
- ▲ Simple Maintenance
- ▲ Higher Vacuum Capabilities
- ▲ Easy to Install
- ▲ Quiet Operation



Product Options

- ▲ Air Filter (recommended)
- ▲ Vacuum Regulating Valve
- ▲ Exhaust Silencer
- ▲ Vacuum Gauge

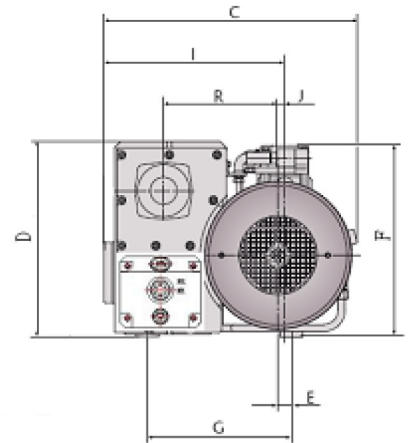
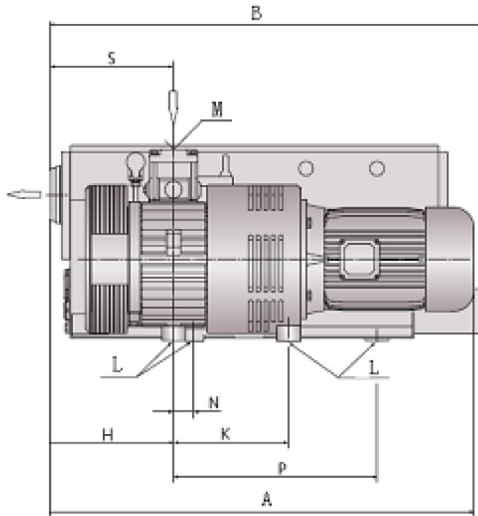

A	B	C	D	E	F	G	H	I	J	K	L	M	N	P
32.87	33.66	19.49	17.12	0.98	16.73	12.20	8.86	13.58	0.59	9.45	4*M10	2	1.38	16.53

Model	Capacity Max cfm		Ultimate Vacuum Max. (in Hg)		Motor Output Full Load (HP)		Voltage 3Phase (V)		Noise Level (dB)		Weight (lb)
	50 Hz	60 Hz	50 Hz	60 Hz	50 Hz	60 Hz	50 Hz	60 Hz	50 Hz	60 Hz	
RX-160	94.2	117.0	29.92	29.92	5.50	7.50	220-380	230-460	71.0	71.0	346



Republic Vacuum Pump RX 160

REPUBLIC
Vacuum Pumps®

RX 160 Vacuum Curves

