



Republic Combination Pump DVT-425K

REPUBLIC
Vacuum Pumps®

Republic offers the DVT-425K dry running rotary vane vacuum/pressure combination pump with an integral suction air filter. Sound cover reduces noise level, enhances cooling and protects operator from touching hot surfaces. Flexible connections possible, low pulsation, easy to operate, maintain and install.



Advantages

- ▲ Absolutely oil-free
- ▲ Free moving vanes
- ▲ Lower initial cost
- ▲ Higher vacuum capabilities

Product Options

- ▲ Air filter (recommended)
- ▲ Vacuum regulating valve
- ▲ Non-return valve

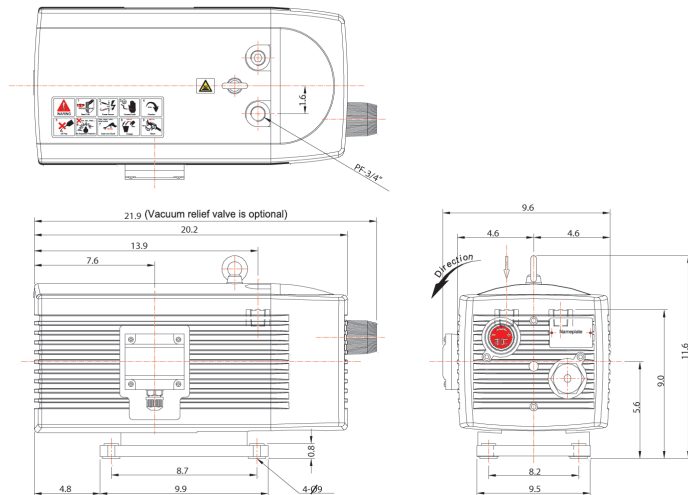

Motor Output Full Load (HP)		Capacity Max cfm		Max Pressure (psig)		Ultimate Vacuum Max. (in Hg)		Voltage 3Phase (V)		Noise Level (dB)		Weight (lb)
50 Hz	60 Hz	50 Hz	60 Hz	50 Hz	60 Hz	50 Hz	60 Hz	50 Hz	60 Hz	50 Hz	60 Hz	
1.0	1.2	14.7	17.6	9.0	9.0	18.0	18.0	220/380	220/460	69	69	57